

ALP300 保护器

ALP300 Protector

安装使用说明书 V1.6

Installation and Operation Instruction V1.6

安科瑞电气股份有限公司

Acrel Co., Ltd.

申 明

DECLARATION

版权所有，未经本公司之书面许可，此手册中任何段落，章节内容均不得被摘抄、拷贝或以任何形式复制、传播，否则一切后果由违者自负。

本公司保留一切法律权利。

No part of this publication may be reproduced, stored in a retrieval system, or transmitted in any form by any means, electronic, mechanical photocopying, recording, or otherwise without prior permission of Acrel. All rights reserved.

本公司保留对本手册所描述之产品规格进行修改的权利，恕不另行通知。订货前，请垂询当地代理商以获悉本产品的最新规格。

This company reserve power of revision of product specification described in this manual, without notice. Before ordering, please consult local agent for the latest specification of product.

目 录

CONTENTS

ALP300 保护器

ALP300 Protector

1 概述 Overview.....	1
2 产品型号 Product type.....	1
3 通用技术指标 General technical index.....	2
4 外形尺寸及安装 Overall dimensions and installation.....	3
5 显示与用户编程 Display and user programming.....	5
6 接线方式 Wiring Mode.....	10
7 通讯协议 Communication protocol.....	10
8 典型应用方案 Typical application scheme.....	22
9 保护功能设置及说明 Setting and description of protection functions.....	24
10 注意事项 Cautions.....	28
11 订货范例 Order sample.....	29

警告：用户在使用该保护器之前，请务必按所要保护电动机的实际情况对各项保护功能及保护参数进行设置。

Warning. User must set protective functions and parameters in accordance with conditions of your motor before using the protector.

1 概述 Overview

ALP300 保护器（以下简称保护器），采用最新的单片机技术，具有抗干扰能力强、工作稳定可靠、数字化、智能化等特点。保护器能对电动机运行过程中出现的起动超时、过压、欠压、过载、断相、不平衡、欠载、接地/漏电、阻塞、短路、外部故障等多种情况进行保护，现场维护人员可通过数码管显示屏快速查找故障原因。本保护器具有 RS485 远程通讯接口，DC4~20mA 模拟量输出，方便与 PLC、PC 等控制机组成网络系统，实现电动机运行的远程监控。ALP300 protector (hereinafter referred to as protector) adopts the latest single-chip microcomputer technology and has features of strong capacity of resisting disturbance, stable and reliable working, digitization and intellectualization and so on. The protector can protect the motor during operation in case of overtime starting, under-voltage, over-voltage, over-load, open phase, unbalance, under-load, ground/electric leak, blocking, short circuit and external faults and so on. The field maintenance personnel may rapidly find the fault cause with the digit display. The protector has RS485 remote communication interface and DC4 ~ 20mA analog quantity output to compose the network system with PLC and PC control units and to achieve remote monitoring of motor operation.

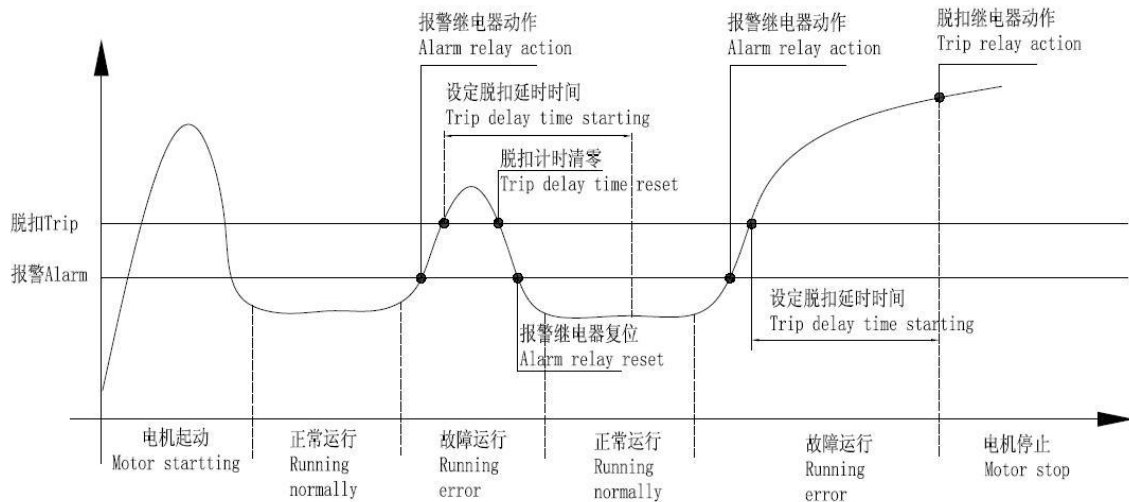

保护器动作示意图
Schematic diagram

2 产品型号 Product type

ALP300 - /

附加功能: C-通讯 M-变送 K-开关量 J-报警 L-漏电
 电流规格: 5, 25, 100
 公司代号



表 1

Table 1

电流规格 Current specification	可设定额定电流 Set rated current
5	1-6000(设置变比) 1-6000(Ratio setting)
25	6-25
100	25-60

注：100A 电流规格的 ALP300 保护器，只适用于额定电流小于 60A 的电动机，额定电流大于 60A 的电机推荐选用 5A 规格的保护器。选择 100A 规格时，推荐使用 6-10 平方的铜芯电缆线。

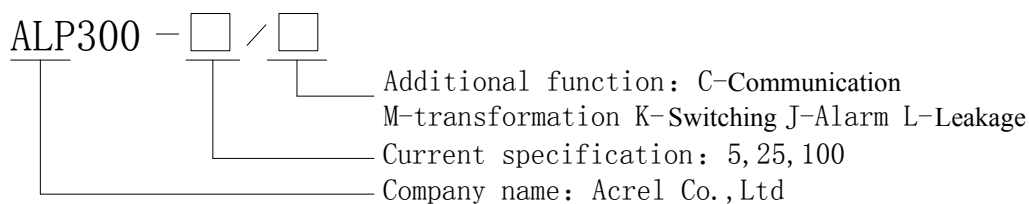
Note:100A current specification protector only suit for the motor with rated current less than 60A.Motor with rated current greater than 60A is recommended to use 5A protector.When choosing 100A specification,it is recommended to use 6-10 square millimeter copper core cable.

表 2

Table 2

附加功能 Additional function	代号 Code	附加功能 Additional function	代号 Code
通讯接口 Communication interface	C	4~20mA 模拟量输出 Analog output 4-20mA	M
漏电保护 Leakage protection	L	报警输出（可编程 2） Alarm output (programmable 2)	J
2 路开关量输入；1 路继电器输出（可编程 3） 2-way switching input, 1-way relay output (programmable 3)			K

3 通用技术指标 General technical index

表 3

Table 3

技术参数 Technical parameters	技术指标 Technical specification	
保护器辅助电源 Auxiliary power supply of protector	AC85V~265V	
电机额定工作电压 Rated working voltage of motor	AC380V, 50Hz/60Hz	
继电器输出触点，额定负载容量 Rated working voltage of motor, rated load capacity	4 路 AC250V, 3A; DC30V, 3A 4-way, AC250V,3A;DC30V,3A	
开关量输入 Switching input	2 路，光电隔离 2-way, optical isolation	
通讯 Communication	RS485 Modbus 协议 RS485 Modbus Protocol	
环境 Environment	工作温度 Working temperature	-10°C~55°C
	贮存温度 Storage temperature	-20°C~65°C

	相对湿度 Relative humidity	5%~95% 不结露 5%-95%, no dew
	海拔 Altitude	≤2000m
污染等级 Class of pollution	2	
防护等级 Protection level	IP30	

4 外形尺寸及安装 Overall dimensions and installation

4.1 保护器安装尺寸图(单位: mm) Installation dimensions of protector(Unit: mm)



主视图 Front view

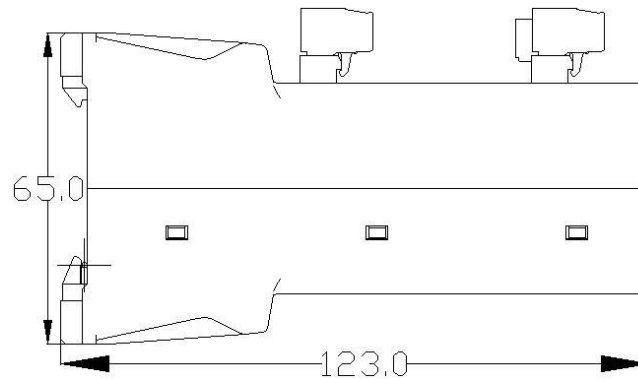

左视图 Left view

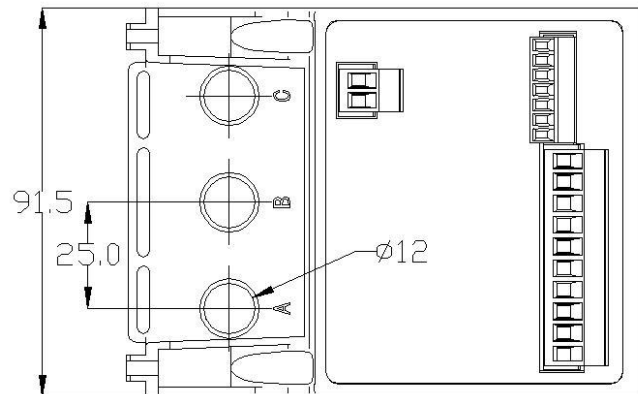

俯视图 Overlook view

4.2 漏电互感器安装尺寸

Installation dimensions of zero sequence current transformer

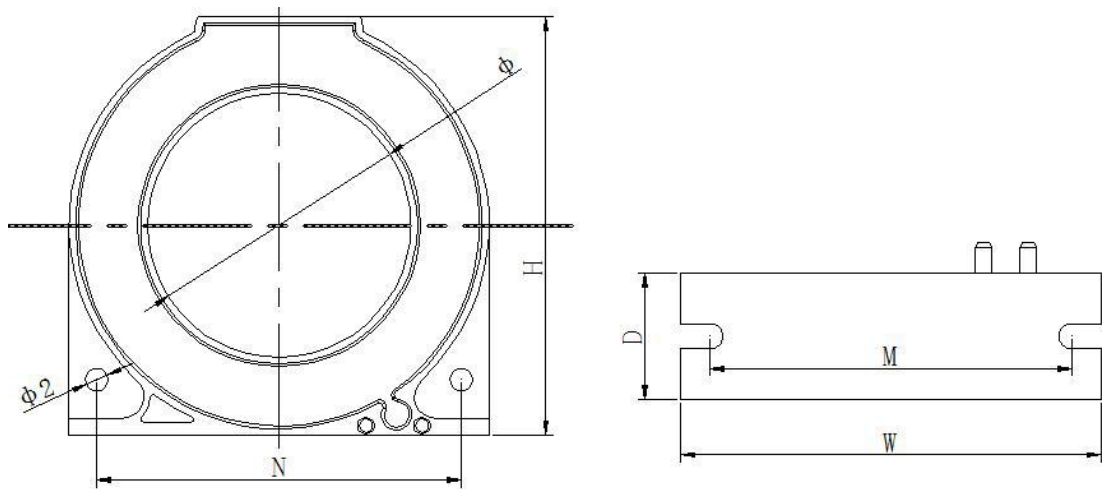

互感器部分

Zero sequence current transformer

尺寸 Size 规格 Standard	额定电流 (A) Current specification (A)	外形尺寸(mm) Outline dimension(mm)			穿孔尺寸(mm) Perforation Size(mm)	安装尺寸(mm) Installation Size(mm)			公差 (mm) Tolerance (mm)	重量 (g) Weight (g)
		W	H	D	Φ	M	N	Φ2		
L-45	16-100	75	75	22	46	65	65	4	±1	200±10
L-80	100-250	120	120	23	81	105	105	4		380±20
L-150	400-800	196	205	24	150	175	180	6		850±50

4.3 安装方法 Installation method

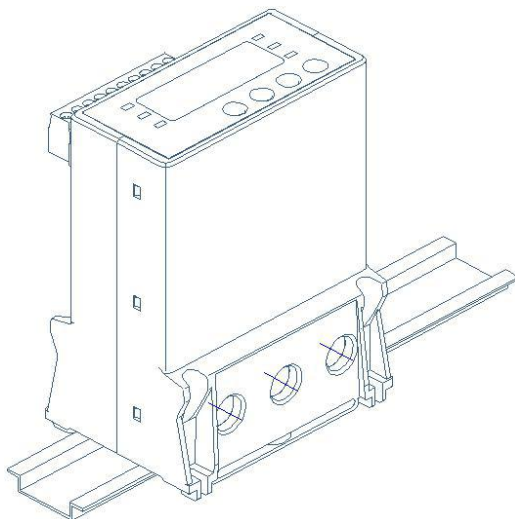

导轨安装方式
installed by the guide rail

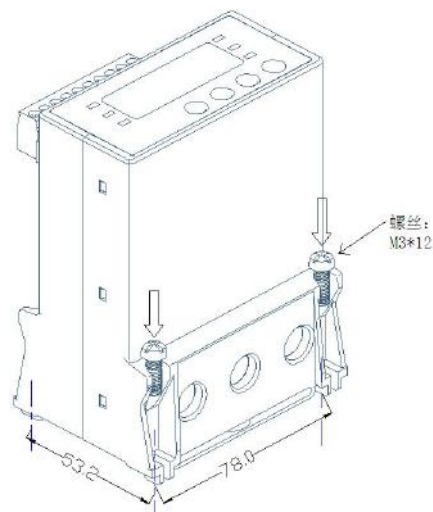

螺丝固定方式
fixed by screws

注：ALP300 保护器可以采用导轨安装，直接卡接在 35mm 导轨上；或采用 M3 螺丝固定方式安装，其中螺丝长度应大于等于 12mm。

Note: the ALP300 protector may be installed by the guide rail and is directly clamped on 35mm guide rail; or the protector is fixed by M3 screws. The screw shall be no less than 12mm.

5 显示与用户编程 Display and user programming

5.1 数码管显示说明 Description of LED display



表 4
Table 4

序号 No.	名称 Name	状态 Status	功能说明 Functional description
1	A 相 LED 指示灯 A-phase LED indicator	亮/灭 On/Off	亮表明显示值为 A 相电流 If the indicator is ON, it indicates that the displayed value is A-phase current
2	B 相 LED 指示灯 B-phase LED indicator	亮/灭 On/Off	亮表明显示值为 B 相电流 If the indicator is ON, it indicates that the displayed value is B-phase current
3	C 相 LED 指示灯 C-phase LED indicator	亮/灭 On/Off	亮表明显示值为 C 相电流 If the indicator is ON, it indicates that the displayed value is C-phase current
4	Run LED 指示灯 Run LED indicator	亮/灭 On/Off	亮表明电动机处于运行状态 If the indicator is ON, it indicates that the motor is at operation state
5	Trip LED 指示灯 Trip LED indicator	亮/灭 On/Off	亮表明电动机发生故障，A 脱扣继电器已动作 If the indicator is ON, it indicates that the motor has a fault and A tripping relay has already acted.
6	Alarm LED 指示灯 Alarm LED indicator	亮/灭 On/Off	亮表明 A 报警，A 已报警 If the indicator is ON, it indicates A alarms, A has already alarmed
7	 确定键 Confirm button	按下 Hold down	进入菜单，设定状态下确认修改的参数 Enter the menu and confirm the modified parameter under the set condition
8	 方向键 Arrow key	按下 Hold down	上翻菜单或更改数据值 Drop up the menu or change the data
9	 方向键 Arrow key	按下 Hold down	下翻菜单或更改数据值 Drop down the menu or change the data
10	 取消键 Cancel button	按下 Hold down	退出菜单或取消修改操作或将 A 复位 Exit the menu, delete the modifying operation or reset A
11	4 位 LED 数码管 4-bit LED digit tube	0000	显示各种测量参数、设置参数及故障类型 Display all measured parameters, set parameters and fault types
注 Notes	A、B、C 相指示灯 A, B and C-phase indicator	全亮 All ON	指示灯全亮则表明显示值为三相平均电流 If all indicators are ON, it indicates that the displayed value is the three-phase mean current.

5.1.1 用户编程 User programming

按保护器上的“←”键，至显示“P001”，按“←”键和“→”键用于菜单的选择，到相应的菜单序号后，按“←”键，进入值域的设置，按“←”键进行数据位的选择，按“→”键用于数字的增加，所需参数设置完毕后，按“←”键进行保存，再按“Esc”键退出菜单。其中，保护器的各种保护功能的打开与否用“ON”“OFF”表示。参数设置见下表：

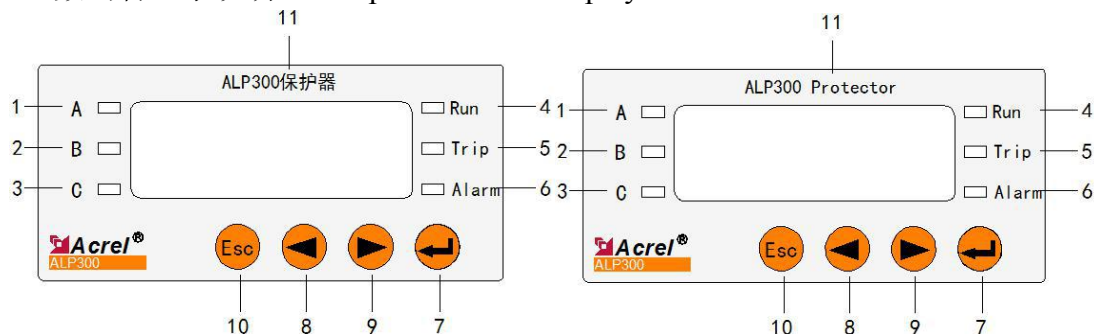
Press “←” key on the protector until “P001” is displayed. Press “←” key and “→” key to select the menu. Enter the corresponding menu number, press “←” key and enter the setting of range. Press “←” key to select the data bit. Press “→” key to increase the number. After all parameters are set, press “←” key to save the settings. Later, press “Esc” to exit the menu. The on and off of all protection functions of protector are expressed by “ON” and “OFF”. For the parameter setting, see the table below:

面板参数 Parameter	设定类别 Class setting	默认值 Default value	设定范围 Setting ranges	单位 Unit
P001	额定电流 Rated current	1.6	0.1-6000.0	安培 A
P002	定时限过载阈值 Constant time lag over-load threshold	150	100-700	%
P003	过载报警值 Overload alarm threshold	90	1-700	%
P004	定时限过载延时 Constant time lag over-load delayed	5	0.1-600.0	秒 Second
P005	欠载脱扣阈值 Under-load tripping threshold	50	10-99	%
P006	欠载报警阈值 Under-load alarm threshold	50	10-99	%
P007	欠载脱扣延时 Under-load tripping delayed	5	0.1-600.0	秒 Second
P008	漏电故障电流 Leakage fault current	300	30-1000	毫安 Milliampere
P009	漏电报警电流 Leakage alarm current	300	30-1000	毫安 Milliampere
P010	接地脱扣百分比 Earthing tripping percentage	80	20-100	%
P011	接地报警百分比 Earthing alarm percentage	60	20-100	%
P012	接地/漏电脱扣延时 Earthing/ leakage tripping delayed	0.5	0.1-600.0	秒 Second
P013	不平衡脱扣阈值 Unbalance tripping threshold	30	10-99	%
P014	不平衡报警阈值 Unbalance	20	10-99	%

	alarm threshold			
P015	不平衡脱扣延时 Unbalance tripping delayed	5	0.1-600.0	秒 Second
P016	短路脱扣阈值 Short-circuit tripping threshold	400	400-700	%
P017	短路报警阈值 Short-circuit alarm threshold	400	400-700	%
P018	短路脱扣延时 Short-circuit tripping delayed	0.1	0.1-600.0	秒 Second
P019	阻塞脱扣阈值 Blocking tripping threshold	250	100-700	%
P020	阻塞报警阈值 Blocking alarm threshold	250	100-700	%
P021	阻塞脱扣延时 Blocking tripping delayed	5	0.1-600.0	秒 Second
P022	堵转脱扣阈值 Locked-rotor tripping threshold	600	100-700	%
P023	堵转报警阈值 Locked-rotor alarm threshold	600	100-700	%
P024	堵转脱扣延时 Locked-rotor tripping delayed	5	0.1-600.0	秒 Second
P025	断相脱扣延时 Phase failure tripping delayed	1	0.1-600.0	秒 Second
P026	外部故障脱扣延时 External fault tripping delayed	5	0.1-600.0	秒 Second
P027	过压脱扣阈值 Over-voltage tripping threshold	120	110-150	%
P028	过压脱扣延时 Over-voltage tripping delayed	5	0.1-600.0	秒 Second
P029	欠压脱扣阈值 Under voltage tripping threshold	80	55-90	%
P030	欠压脱扣延时 Over-voltage tripping delayed	5	0.1-600.0	秒 Second
P031	漏电互感器投入 Electric leakage transformer input	0	0-1	
P032	反时限过载脱扣允许 Inverse time limit over-load tripping allowed	ON	OFF/ON	
P033	接地脱扣允许 Grounding tripping allowed	OFF	OFF/ON	
P034	漏电脱扣允许 Electric leakage tripping allowed	OFF	OFF/ON	
P035	欠载脱扣允许 Under-load tripping allowed	OFF	OFF/ON	
P036	断相脱扣允许 Open phase tripping allowed	ON	OFF/ON	
P037	堵转脱扣允许 Locked rotor tripping allowed	OFF	OFF/ON	
P038	阻塞脱扣允许 Blocking tripping allowed	OFF	OFF/ON	

P039	不平衡脱扣允许 Unbalanced tripping allowed	OFF	OFF/ON	
P040	外部故障脱扣允许 External fault tripping allowed	OFF	OFF/ON	
P041	起动超时脱扣允许 Start timeout tripping allowed	ON	OFF/ON	
P042	短路脱扣允许 Short circuit tripping allowed	OFF	OFF/ON	
P043	定时限过载脱扣允许 Constant time lag tripping allowed	OFF	OFF/ON	
P044	过压脱扣允许 Over-voltage tripping allowed	OFF	OFF/ON	
P045	欠压脱扣允许 Under-voltage tripping allowed	OFF	OFF/ON	
P046	反时限过载报警允许 Inverse time lag over-load alarm allowed	OFF	OFF/ON	
P047	断相报警允许 Open phase alarm allowed	OFF	OFF/ON	
P048	阻塞报警允许 Blocking alarm allowed	OFF	OFF/ON	
P049	不平衡报警允许 Unbalanced alarm allowed	OFF	OFF/ON	
P050	外部故障报警允许 External fault alarm allowed	OFF	OFF/ON	
P051	定时限过载报警允许 Constant time lag over-load alarm allowed	OFF	OFF/ON	
P052	可编程 1 继电器输出设定 Programmable 1 relay output setting	10	0 远程起动 1 报警 2 脱扣 3 过载 4 短路 5 接地/漏电脱扣 6 断相 7 外部故障 8 漏 电报警 9 短路、接地保护 10 短路、接 地/漏电 11 短路、接地/漏电 (脉冲 1s) 0. remote starting 1.alarm 2.trip 3.overload 4.short circuit 5.earthing/leakage trip 6. phase failure 7. xternal fault 8. leakage alarm 9. short circuit and earthing protection 10.short circuit, leakage/earthing 11. short circuit, leakage/earthing (pulse: 1s)	
P053	可编程 2 继电器输出设定 Programmable 2 electric relay output setting	1	同上 Ditto	
P054	可编程 3 继电器输出设定 Programmable 3 electric relay output setting	0	同上 Ditto	
P055	脱扣等级 Overload/ full-load rated current setting	5	1、2、3、5、10、15、20、25、30、35、 40	级 Level
P056	MODBUS 波特率 Baud rate of MODBUS	3-1920 0	0-2400, 1-4800, 2-9600, 3-19200, 4-38400	bps
P057	MODBUS 地址 MODBUS address	1	1-247	

P058	CT 变比 CT transformation ratio	1	1-6300 (1990)	
P059	起动时间 Starting time	10	0.1-600.0	秒 Second
P060	次级电流值 Secondary current value	5A	1、5A	
P061	冷却时间 Cooling time	0	0-30	分 Minutes
P062	过压报警阈值 Over-voltage alarm threshold	110	110-150	%
P063	欠压报警阈值 Under voltage alarm threshold	90	55-90	%
P064	接地报警允许 Earthing alarm allowed	OFF	OFF/ON	
P065	漏电报警允许 Leakage alarm allowed	OFF	OFF/ON	
P066	欠载报警允许 Under-load alarm allowed	OFF	OFF/ON	
P067	堵转报警允许 Locked rotor alarm allowed	OFF	OFF/ON	
P068	起动超时报警允许 Start timeout alarm allowed	OFF	OFF/ON	
P069	短路报警允许 Short circuit alarm allowed	OFF	OFF/ON	
P070	过压报警允许 Over-voltage alarm allowed	OFF	OFF/ON	
P071	欠压报警允许 Under-voltage alarm allowed	OFF	OFF/ON	

5.1.2 查看数据 View data

测量数据查看：用户可按动“”键，切换显示三相平均电流、A 相电流、B 相电流、C 相电流、漏电流或接地电流百分比、电压、开关量输入。

View measured data: the user may press “” key to shift the display of three-phase mean current, A-phase current, B-phase current, C-phase current, leakage current or grounding current percentage, voltage and switching input.

故障显示说明：

Description of fault display:

表 6
Table 6

显示 Message	故障原因 Fault cause
hEAt	过载 Overload
oUdf	接地/漏电 Earthing/leakage
UdCU	欠载 Under-load
LoPh	断相 Phase failure
StAl	堵转 Locked-rotor
JA	阻塞 Blocking
CUIb	电流不平衡 Current unbalance
oUtE	外部故障

	External fault
Stot	起动超时 Starting time-out
shor	短路 Short circuit
ouuo	过压 Over-voltage
Uduo	欠压 Under-voltage
ouCU	定时限过载 constant time lag over-load

6 接线方式 Wiring Mode

6.1 电源接线 Auxiliary power supply

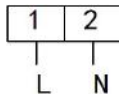

辅助电源 Auxiliary power supply

6.2 继电器输出 Relay output



脱扣

Trip

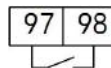

脱扣 (可编程 1)

trip (programmable 1)

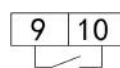

报警 (可编程 2)

Alarm (programmable 2)

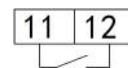

可编程 3

programmable 3

6.3 RS485 通讯 RS485 communication

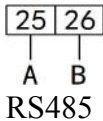

RS485

6.4 DC4~20mA 模拟量输出 Analog output DC4-20mA



DC4~20mA

6.5 开关量输入 Switching input

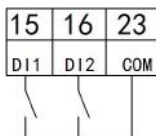

6.6 零序电流输入 Input of zero-sequence current

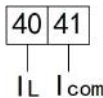

7 通讯协议 Communication protocol

7.1 通讯协议概述 Overview of communication protocol

保护器使用 MODBUS-RTU 通讯协议，MODBUS-RTU 协议详细定义了校验码、数据序列等，这些都是特定数据交换的必要内容。MODBUS-RTU 协议在一根通讯线上使用主从应答式连接（半双工），这意味着在一根单独的通讯线上信号沿着相反的两个方向传输。首先，主计算机的信号寻址到一台唯一的终

端设备（从机），然后，终端设备发出的应答信号以相反的方向传输给主机。MODBUS-RTU communication protocol is adopted for the protector. MODBUS-RTU protocol defines the check code and data series and so on in details. These are the required contents for specific data exchange. MODBUS-RTU protocol uses the master-slave response connection (half-duplex) on one communication line, which means the signals on one single communication line are transmitted along two inverse directions. First, the signals on the master computer finds one unique terminal equipment (slave computer) by addressing. Later, the answering signal from the terminal equipment is transmitted to the master computer along the inverse direction.

MODBUS-RTU 协议只允许在主机（PC，PLC 等）和终端设备之间通讯，而不允许独立的终端设备之间的数据交换，这样各终端设备不会在它们初始化时占据通讯线路，而仅限于响应到达本机的查询信号。

MODBUS-RTU protocol only allows the communication between the master computer (Pc and PLC) rather than the data exchange among the separate terminal equipment. Thus, all terminal equipment will not occupy the communication line during initialization but only responds to the query signals arrived.

7.1.1 传输方式 Transmission mode

信息传输为异步方式，并以字节为单位，在主机和从机之间传递的通讯信息是 11 位字格式，包含 1 个起始位、8 个数据位（最小的有效位先发送）、无奇偶校验位、1 个停止位。

Asynchronous mode is adopted for the information transmission and byte is used as the unit. The communication information transmitted between the master computer and slave computer is in 11-bit word format, including 1 start bit, 8 data bits (the minimum effective bit is transmitted first), no parity check code and 1 stop bit.

7.1.2 信息帧格式 Information frame format

地址码 Address code	功能码 Function code	数据区 Data field	CRC 校验码 CRC check code
1 字节	1 字节	n 字节	2 字节

地址码：地址码在帧的开始部分，由一个字节（8 位二进制码）组成，十进制为 0~255，在 ALP300 中只使用 1-247,其它地址保留。这些位标明了用户指定的终端设备的地址，该设备将接收来自与之相连的主机数据。每个终端设备的地址必须是唯一的，仅仅被寻址到的终端会响应包含了该地址的查询。当终端发送回一个响应，响应中的从机地址数据便告诉了主机哪台终端正与之进行通信。

Address code: the starting part of address code in the frame is composed of one byte (8-bit binary code). The decimal is 0~255, 1-247 are only used in ALP300 and other addresses are saved. These bits mark the address of terminal equipment designed by the user. The equipment will receive the data from the connected master computer. Each terminal equipment address must be unique and the only the addressed terminal will respond to the address request. When the terminal sends a response, the slave computer address data in the response will tell which terminal of

the master computer conducts the communication.

功能码：功能码告诉了被寻址到的终端执行何种功能。下表列出了 ALP300 用到的功能码，以及它们的意义和功能。

Function code: the function code indicates which the addressed terminal performs what kind of function. The function codes used in the ALP300 and the meanings and functions are listed in the table below.

功能 Function	定义 Definition	操作 Operation
03H/04H	读数据寄存器 Read data register	获得一个或多个寄存器的当前二进制值 Get one or multiple registers' current binary value
10H	预置多寄存器 Preset multiple registers	设定二进制值到一系列多寄存器中 Set binary value in a series of multiple registers
06H	预置单个寄存器 Preset single register	设定二进制值到单个寄存器中 Set binary value in single register

数据区：数据区包含了终端执行特定功能所需要的数据或者终端响应查询时采集到的数据。这些数据的内容可能是数值、参考地址或者设置值。例如：功能码告诉终端读取一个寄存器，数据区则需要指明从哪个寄存器开始及读取多少个数据，内嵌的地址和数据依照类型和从机之间的不同内容而有所不同。

Data field: the data field includes the data required for the terminal executing the specific functions or data acquired for the terminal response query. The data may be value, reference address or set value. E.g.: the function code tells the terminal to read one register. The data area needs to specify which register begins and reads how many data. The embedded address and data may be different according to the types and different contents of the slave computer.

CRC 校验码：错误校验（CRC）域占用两个字节，包含了一个 16 位的二进制值。CRC 值由传输设备计算出来，然后附加到数据帧上，接收设备在接收数据时重新计算 CRC 值，然后与接收到的 CRC 域中的值进行比较，如果这两个值不相等，就发生了错误。

CRC check code: error check (CRC) field occupies two bytes and includes one 16-bit binary value. CRC value is calculated by the transmission equipment and then is added to the data frame. The receiving equipment will calculate CRC value when receiving the data. Later, it will compare the calculated value with the value in the CRC field. If two values are not equal, there is an error.

生成一个 CRC 的流程为：

One CRC process generated is:

- (1) 预置一个 16 位寄存器为 0FFFFH（全 1），称之为 CRC 寄存器。
(1) Preset one 16-bit register, that is, 0FFFFH (full 1). It is known as CRC register.
- (2) 把数据帧中的第一个字节的 8 位与 CRC 寄存器中的低字节进行异或运算，结果存回 CRC 寄存器。
(2) Conduct the exclusive or operation with the 8 bits of the first byte in the data frame and low byte of CRC register. The result is saved in CRC register.
- (3) 将 CRC 寄存器向右移一位，最高位填以 0，最低位移出并检测。
(3) Shift the CRC register to the right with one bit. Write 0 in the highest bit, shift out the lowest bit and conduct the detection.
- (4) 如果最低位为 0，重复第三步（下一次移位）；如果最低位为 1，将 CRC 寄存器与一个预设的固定值（0A001H）进行异或运算。
(4) If the lowest bit is 0, repeat step 3 (shift next time); if the lowest bit is 1, conduct

the exclusive or operation with the CRC register and one preset fixed value (0A001H).

(5) 重复第三步和第四步直到 8 次移位，这样处理完了一个完整的八位。

(5) Repeat Steps 3 and 4 to shift for the 8th time. Thus, a full eight-bit data is handled.

(6) 重复第 2 步到第 5 步来处理下一个八位，直到所有的字节处理结束。

(6) Repeat Step 2 to Step 5 to handle the next eight bits until all bytes are handled.

(7) 最终 CRC 寄存器的值就是 CRC 的值。

(7) The final CRC register value is CRC value.

此外还有一种利用预设的表格计算 CRC 的方法，它的主要特点是计算速度快，但是表格需要较大的存储空间，该方法此处不再赘述，请参阅相关资料。In addition, CRC will be calculated with the default form. It has main features of rapid calculation speed and larger storage space. This method is not described here and you may refer to the relevant information.

7.2 功能码简介 Introduction to function code

7.2.1 功能码 03H 或 04H: 读寄存器 Function code 03H or 04H: read register

此功能允许用户获得设备采集与记录的数据及系统参数。主机一次请求的数据个数没有限制，但不能超出定义的地址范围。

With the function, the user is allowed to acquire the data acquired and recorded data and system parameters. The number of data requested by the master computer at a time is not limited but is not beyond the defined address range.

下面的例子是从 01 号从机读 3 个采集到的基本数据（数据帧中每个地址占用 2 个字节）L1、L2、L3，其中 L1 的地址为 0000H, L2 的地址为 0001H, L3 的地址为 0002H。

The following examples show 3 basic data read by No. 01 slave computer (each address of the data frame occupies 2 bytes) L1, L2 and L3. L1 address is 0000H, L2 address is 0001H and L3 address is 0002H.

7.2.2 功能码 10H: 写寄存器

Function code 10H: read register

功能码 10H 允许用户改变多个寄存器的内容，该仪表中系统参数、继电器输出状态等可用此功能号写入。主机一次最多可以写入 8 个（16 字节）数据。The function code 10H allows the user to change the contents of multiple registers. The instrument system parameters and output state may be written in by the function. The master computer may write 8 (16 bytes) data at most at a time.

下面的例子是预置地址为 01 的仪表输出开关量 DO2。开关量输入/输出状态指示寄存器地址为 0003H，第 0-1 位对应 DI1-DI2，第 8-11 位分别对应 DO1-DO4。

The instrument switching output DO2 with 01 preset address is shown below. The switching input/output state indicator register address is 0003H, the 0-1 bits correspond to DI1-DI2, and the 8-11 bits respectively correspond to DO1-DO4.

主机发送 Information sent by the master unit		发送信息 Code	从机返回 Information sent by the slave unit		返回信息 Code
地址码 Address code		01H	地址码 Address code		01H
功能码 Function code		10H	功能码 Function code		10H
起始地址	高字节	00H	起始地址	高字节	00H

Start address	High byte	
	低字节 Low byte	03H
寄存器数量 Number of registers	高字节 High byte	00H
	低字节 Low byte	01H
字节数 Number of bytes		02H
0003H 待写入数据 Data to be preset in 0003H	高字节 High byte	04H
	低字节 Low byte	00H
CRC 校验码 CRC check code	低字节 Low byte	A3H
	高字节 High byte	A4H

Start address	High byte	
	低字节 Low byte	03H
寄存器数量 Number of registers	高字节 High byte	00H
	低字节 Low byte	01H
CRC 校验码 CRC check code	低字节 Low byte	C9H
	高字节 High byte	F1H

7.2.3 功能码 06H: 写单个寄存器 Function code 06H: preset the single register

功能码 06H 允许用户改变单个寄存器的内容, 该仪表中系统参数、开关量输出状态等可用此功能号写入。

下面的例子是预置地址为01的仪表输出开关量DO2。开关量输入/输出状态指示寄存器地址为0003H, 第0-1位对应DI1-DI2, 第8-11位分别对应DO1-DO4。

主机发送 Information sent by the master unit		发送信息 Code	从机返回 Information sent by the slave unit		返回信息 Code
地址码 Address code		01H	地址码 Address code		01H
功能码 Function code		06H	功能码 Function code		06H
起始地址 Start address	高字节 High byte	00H	起始地址 Start address	高字节 High byte	00H
	低字节 Low byte	03H		低字节 Low byte	03H
0003H 待写入数据 Data to be preset 0003H	高字节 High byte	04H	写入数据 Data to be set	高字节 High byte	04H
	低字节 Low byte	00H		低字节 Low byte	00H
CRC 校验码 CRC check code	低字节 Low byte	0AH	CRC 校验码 CRC check code	低字节 Low byte	0AH
	高字节 High byte	7BH		高字节 High byte	7BH

7.3 地址参量 Address parameters

表 7

Table 7

序号 NO.	地址 Address	参数 Parameter	读写属性 Read-write property	数值范围 Numerical range	备注 Remark
1	0000	A 相电流 A-phase current	R	0-65535	

2	0001	B相电流 B-phase current	R	0-65535	
3	0002	C相电流 C-phase current	R	0-65535	
4	0003	平均电流 Mean current	R	0-65535	
5	0004	漏电流/接地电流百分比 Leakage current/grounding current percentage	R	漏电流: 30-100mA Leakage current: 30-100mA	接地电流百分比: 1-100% Grounding current percentage: 1-100%
6	0005	电流不平衡度 Current unbalanced degree	R	0-100%	
7	0006	累计热容量百分比 Accumulated heat capacity percentage	R	0-100%	
8	0007	系统频率 System frequency	R	50、60	
9	0008	电机状态 Motor state	R	高字节: 电机过载 剩余冷却时间 High byte: residual cooling time of motor over-load	Bit0 停车 Bit1 起动 Bit2 运行 Bit3 报警 Bit4 脱扣 Bit0 stop Bit1 start Bit2 operation Bit3 alarm Bit4 trip
10	0009	脱扣故障指示 Tripping fault indication			Bit0 起动超时 Bit1 定时限过载 Bit2 反时限过载 Bit3 堵转 Bit4 阻塞 Bit5 短路 Bit6 接地 Bit7 欠载 Bit8 断相 Bit9 不平衡 Bit10 漏电 Bit11 外部故障 Bit12 过压 Bit13 欠压 Bit0 start timeout Bit1 constant time lag over-load Bit2 inverse time lag over-load Bit3 locked rotor Bit4 blocking Bit5 short circuit Bit6 grounding Bit7 under-load Bit8 open phase Bit9 unbalanced Bit 10 electric leakage Bit11 external fault Bit12 over-voltage Bit13 under-voltage
11	000A	DIDO 状态 DIDO state	R	Bit0、Bit1 对应 DI1、DI2 Bit0、Bit1 correspond to DI1、DI2	Bit8~Bit11 对应 DO1~DO4 Bit8~Bit11 correspond to DO1~DO4
12	000B	电压 Voltage	R	0-65535	
13	000C	本次电机运行时	R	0-65535 小时	

		间 Motor run time this time		0-65535 hour	
14	000D	本次电机停车时 间 Motor stopping time this time	R	0-65535 小时 0-65535 hour	
15	000E	电流比例因子 Current scale factor	R	10、100、1000	
16	000F	软件版本号 Software version number	R	1.00-100.00	
17	0010	预留 Reserved			
18	0011	预留 Reserved			
19	0012	预留 Reserved			
20	0013	预留 Reserved			
21	0014	预留 Reserved			
22	0015	电流规格 Current specification	R	1-3	电流规格： 1-5、2-25、3-100 Current specification: 1-5, 2-25 and 3-100
23	0016	脱扣等级 Tripping level	R/W	1、2、3、5、10、 15、20、25、30、 35、40	
24	0017	定时限过载脱扣 阈值 Constant time lag over-load tripping threshold	R/W	100%-700%	
25	0018	过载报警阈值 Over-load alarm threshold	R/W	1-99%	定时限过载可以到 700% The constant time-lag overload can reach 700%
26	0019	定时限过载脱扣 延时 Constant time lag over-load tripping delayed	R/W	0.1-600.0	
27	001A	欠载脱扣阈值 Under-load tripping threshold	R/W	10-99%	
28	001B	欠载报警阈值 Under-load alarm threshold	R/W	10-99%	
29	001C	欠载脱扣延时 Under-load tripping delayed	R/W	0.1-600.0	
30	001D	漏电故障电流 Leakage fault	R/W	30-1000mA	

		current			
31	001E	漏电报警电流 Leakage alarm current	R/W	30-1000mA	
32	001F	接地脱扣百分比 Grounding tripping percentage	R/W	20-100%	
33	0020	接地报警百分比 Grounding alarm percentage	R/W	20-100%	
34	0021	接地/漏电脱扣延时 Grounding/leakage tripping delayed	R/W	0.1-600.0	
35	0022	不平衡脱扣阈值 Unbalanced tripping threshold	R/W	10-99%	
36	0023	不平衡报警阈值 Unbalanced alarm threshold	R/W	10-99%	
37	0024	不平衡脱扣延时 Unbalanced tripping delayed	R/W	0.1-600.0	
38	0025	短路脱扣阈值 Short-circuit tripping threshold	R/W	400%~700%最大可测过载倍数 400%~700% of maximum measureable overload multiples	
39	0026	短路报警阈值 Short-circuit alarm threshold	R/W	400%~700%最大可测过载倍数 400%~700% of maximum measureable overload multiples	
40	0027	短路脱扣延时 Short-circuit tripping delayed	R/W	0.1-600.0	
41	0028	阻塞脱扣阈值 Blocking tripping threshold	R/W	100%-700%	
42	0029	阻塞报警阈值 Blocking alarm threshold	R/W	100%-700%	
43	002A	阻塞脱扣延时 Blocking tripping delayed	R/W	0.1-600.0	
44	002B	堵转脱扣阈值 Locked-rotor tripping threshold	R/W	100%-700%	
45	002C	堵转报警阈值 Locked-rotor alarm threshold	R/W	100%-700%	
46	002D	堵转脱扣延时 Locked-rotor tripping delayed	R/W	0.1-600.0	
47	002E	断相脱扣延时	R/W	0.1-600.0	

		Open-phase tripping delayed			
48	002F	外部故障脱扣延时 External fault tripping delayed	R/W	0.1-600.0	
49	0030	剩余电流互感器投入 Residual current transformer inputted	R/W	0-未投入 1-投入 0-not inputted 1-inputted	
50	0031	脱扣允许位 Tripping allowed bit	R/W		Bit0 反时限过载、Bit1 接地、Bit2 漏电、Bit3 欠载、Bit4 断相、Bit5 堵转、Bit6 阻塞、Bit7 不平衡、Bit8 外部故障、Bit9 起动超时、Bit10 短路、Bit11 定时限过载、Bit12 过压、Bit13 欠压 Bit0 inverse time lag overload, Bit1 grounding, Bit2 electric leakage, Bit3 underload, Bit4 open phase, Bit5 locked-rotor, Bit6 blocking, Bit7 unbalanced, Bit8 external fault, Bit9 start timeout, Bit10 short circuit, Bit11 constant time lag overload, Bit12 over-voltage, Bit13 under-voltage
51	0032	报警允许位 Alarm allowed bit	R/W		Bit0 反时限过载、Bit1 接地、Bit2 漏电、Bit3 欠载、Bit4 断相、Bit5 堵转、Bit6 阻塞、Bit7 不平衡、Bit8 外部故障、Bit9 起动超时、Bit10 短路、Bit11 定时限过载、Bit12 过压、Bit13 欠压 Bit0 inverse time lag overload, Bit1 grounding, Bit2 electric leakage, Bit3 underload, Bit4 open phase, Bit5 locked-rotor, Bit6 blocking, Bit7 unbalanced, Bit8 external fault, Bit9 start timeout, Bit10 short circuit, Bit11 constant time lag overload, Bit12 over-voltage, Bit13 under-voltage
52	0033	写 DO 状态 (06) Write DO state (06)	R/W	普通 DO 时可写 Writable for ordinary DO	Bit0、1-DO1 吸合(3)、断开(0)、Bit2、3-DO2, Bit4、5-DO3, Bit6、7-DO4 1-DO1 picked up (3), interrupted (0)
53	0034	预留 Reserved	R/W		
54	0035	预留 Reserved	R/W		

55	0036	预留 Reserved	R/W		
56	0037	预留 Reserved	R/W		
57	0038	继电器初始状态 Relay original state	R/W	0 开 1 合, Bit0-3: DO1-4 Bit6-7: DI1-2 0 open 1 close, Bit0-3: DO1-4 Bit6-7: DI1-2	
58	0039	可编程 1 继电器 设定 Programmable 1 relay output setting	R/W		0 远程起动 1 报警 2 脱扣 3 过载 4 短路 5 接地/漏电脱扣 6 断相 7 外部故障 8 漏电报警 9 短路、接地保护 10 短路、接地/漏电 11 短路、接地/漏电 (脉冲 1s) 0 remote start 1 alarm 2 trip 3 overload 4 short circuit 5 grounding/leakage tripping 6 open phase 7 external fault 8 leakage alarm 9 short circuit and ground protection 10 short circuit, grounding/electric leakage 11 short circuit, grounding/electric leakage (impulse 1s)
59	003A	可编程 2 继电器 设定 Programmable 2 relay output setting	R/W		同上 Ditto
60	003B	可编程 3 继电器 设定 Programmable 3 relay output setting	R/W		同上 Ditto
61	003C	额定电流 Rated current	R/W	1.0-6000.0	
62	003D	MODBUS 波特率 MODBUS baud rate	R/W	0-2400, 1-4800, 2-9600, 3-19200, 4-38400	
63	003E	MODBUS 地址 MODBUS address	R/W	1-247	
64	003F	CT 变比 CT transformation ratio	R/W	1-6300	1A: 1-6300, 5A: 1-1990
65	0040	电机类型 Motor type	R/W	0 单相, 1 三相四线	

				0: single-phase; 1: 3-phase 4-wire	
66	0041	起动时间 Starting time	R/W	0.1-600.0	
67	0042	年月 Year and month	R/W		06 命令写入 06 command write
68	0043	日时 Date and hour	R/W		06 命令写入 06 command write
69	0044	分秒 Minute and second	R/W		06 命令写入 06 command write
70	0045	总运行时间 Total running time	R/W	0-65535 小时	
71	0046	总停车时间 Total stopping time	R/W	0-65535 小时	
72	0047	总起动次数 Total number of starts	R/W	0-65535	
73	0048	总脱扣次数 Total number of tripping	R/W	0-65535	
74	0049	过载冷却时间 Over-load cooling time	R/W	0-手动复位 1~30min 自动复 位 0-manual reset 1~30min automatic reset	
75	004A	运行值显示顺序 Runtime value display order	R/W	Bit0~Bit3: 0~11 表示地址 0; Bit4~Bit7 代表地 址 1; Bit8~Bit11 代表地址 2; Bit12~Bit15 代表 地址 3; Bit0~Bit3: 0~11 represents address 0; Bit4~Bit7 represents address 1; Bit8~Bit11 represents address 2; Bit12~Bit15 represents address 3;	每个地址可显示 12 个数据中任意一 个, 地址 0~11 分别对应: A 相, B 相, C 相, 平均电流漏电/接地, 不 平衡度, 累计热容量, 频率, 电机 状态, 脱扣故障, DI/DO 状态, 电 压 Each address may display any one of 12 data, address 0~11 respectively responds to: A-phase, B-phase, C-phase, mean current leakage/grounding, unbalanced level, accumulated heat capacity, frequency, motor state, tripping fault, DI/DO state, voltage
76	004B	运行值显示顺序	R/W	Bit0~Bit3 代表地	

		Runtime value display order		址 4... Bit12~Bit15 代表地址 7 Bit0~Bit3 represents address 4...Bit12~Bit15 represents address 7	
77	004C	运行值显示顺序 Runtime value display order	R/W	Bit0~Bit3 代表地址 8... Bit12~Bit15 代表地址 11 Bit0~Bit3 represents address 8...Bit12~Bit15 represents address 11	
78	004D	预留 Reserved			
79	004E	预留 Reserved			
80	004F	变送类型 Transmitting type	R/W	0-6	0-Ia, 1-Ib, 2-Ic, 3-Iav, 4-Imax, 5-U, 6-F
81	0050	变送倍数 Transmitting ratio	R/W	1-8	电流: 1-8, 电压: 1-2, 频率: 65Hz Curent:1-8, voltage: 1-2 Frequency: 65Hz
82	0051	热累计启动定值 Accumulated heat set value	R/W	100%-200%	
83	0052	定时限过载返回系数 Constant time lag over-load return coefficient	R/W	5%-50%	
84	0053	欠载返回系数 Under-load return coefficient	R/W	5%-50%	
85	0054	漏电返回系数 Electric leakage return coefficient	R/W	5%-50%	
86	0055	接地返回系数 Grounding return coefficient	R/W	5%-50%	
87	0056	不平衡返回系数 Unbalanced return		5%-50%	

		coefficient			
88	0057	短路返回系数 Short-circuit return coefficient	R/W	5%-50%	
89	0058	阻塞返回系数 Blocking return coefficient	R/W	5%-50%	
90	0059	堵转返回系数 Locked-rotor return coefficient	R/W	5%-50%	
91	005A	过压脱扣阈值 Over-voltage tripping threshold	R/W	110%-150%	
92	005B	过压报警阈值 Over-voltage alarm threshold	R/W	110%-150%	
93	005C	过压脱扣延时 Over-voltage tripping delayed	R/W	0.1-600.0	
94	005D	过压返回系数 Over-voltage return coefficient	R/W	5%-50%	
95	005E	欠压脱扣阈值 Under-voltage tripping threshold	R/W	55%-90%	
96	005F	欠压报警阈值 Under-voltage alarm threshold	R/W	55%-90%	
97	0060	欠压脱扣延时 Under-voltage tripping delayed	R/W	0.1-600.0	
98	0061	欠压返回系数 Under-voltage return coefficient	R/W	5%-50%	

8 典型应用方案 Typical application scheme

直接起动模式：图中电动机的起动、停车是通过现场按钮来控制的，接触器 QAC 的吸引线圈串进脱扣继电器的常闭触点中。通电后，按下 SF (起动按钮) 时，QAC 吸引线圈得电，使 QAC 的主触头闭合，电动机开始工作；当按下 SS (停车按钮) 时，QAC 吸引线圈失电，使 QAC 主触点释放，电动机停止工作。保护器直接起动电路

Direct starting mode: the motor is controlled by the field button. The sucking coil of contractor QAC is connected with the normally-closed contact of tripping relay in series. Power it on and press SF (start button). Then, QAC sucking coil is

powered on, QAC main contact is closed and the motor starts to work; press SS (stop button), and then QAC sucking coil is powered off and QAC main contact is released, motor stops working. The protector directly starts the circuit.

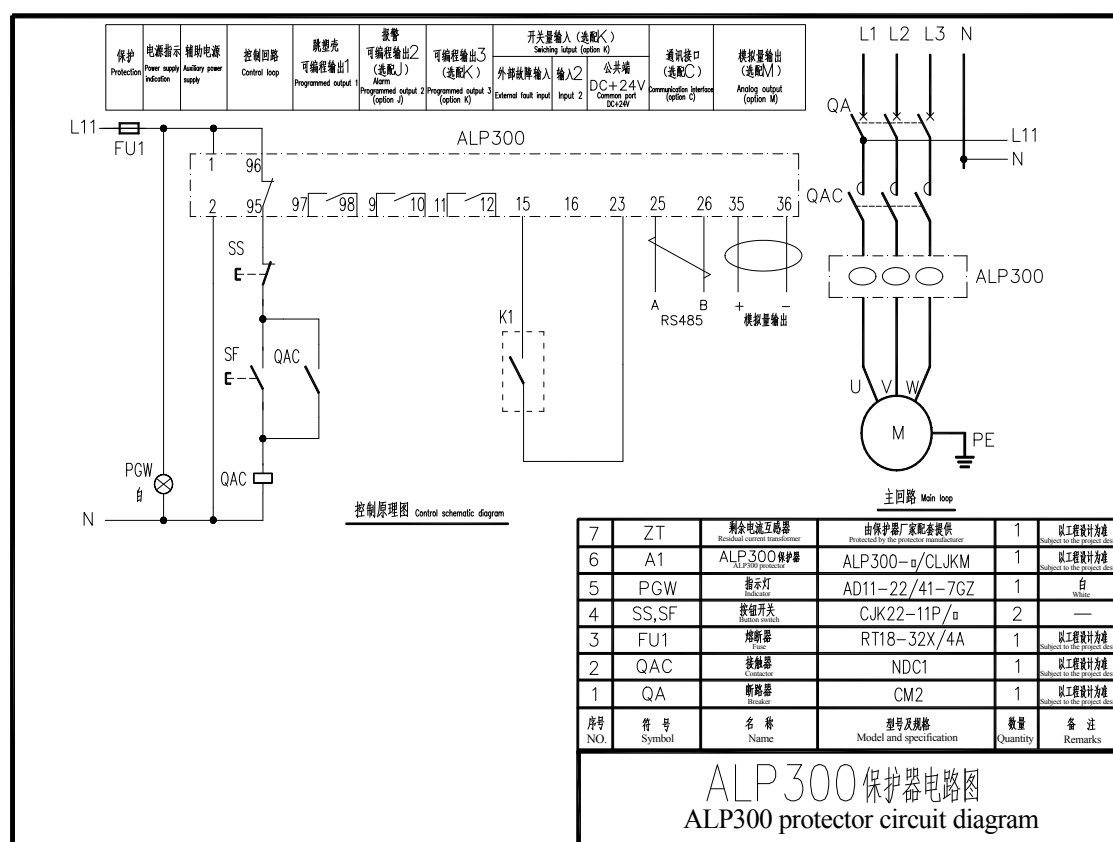

注:

1. 本图应用于 ALP300 保护器的直接起动，其中 97、98 为需要分断断路器的短路、接地等故障输出，需设定为脉冲输出方式，K1 外部故障输入为工艺连锁保护，必选配 K；
2. 保护器可编程输出：
 - (1) 97、98（面板参数：P052）可设定为：0 远程起动 1 报警，2 脱扣，3 过载，4 短路，5 接地、漏电脱扣、6 断相、7 外部故障、8 漏电报警、9 短路、接地保护、10 短路、接地/漏电、11 短路、接地/漏电（脉冲 1S）；
 - (2) 9、10（面板参数：P053）同可编程输出 1 设定；
 - (3) 11、12（面板参数：P054）同可编程输出 1 设定；
3. 本主回路图应用于电流规格为 1/5A/25A/100A 的 ALP300 保护器；
4. 保护器型号仅供参考，可根据需要增选附加功能，不需要的功能可以不接线，保护器上电后 95、96 继电器闭合。

Notes:

1. The diagram applies to ALP300 protector's direct starting. 97 and 98 are fault output, such as short circuit and grounding connection for breaking out breaker and impulse output mode. K1, as the external fault input, is the process interlocking protection, K is required option;
2. Programmed output of protector:
 - (1) 97 and 98 (panel parameters: P052) are set as: 0 remote start 1 alarm, 2 trip, 3 overload, 4 short circuit, 5 grounding connection and leakage tripping, 6 open phase, 7 external fault 8 leakage alarm, 9 short circuit and ground protection, 10 short circuit, grounding

connection/electric leakage, 11 short circuit, grounding connection/electric leakage 9impulse 1S;)

(2) 9 and 10 (panel parameters: P054) are same with programmed output 1 setting;

(3) 11 and 12 (panel parameters: P054) are same with programmed output 1 setting;

3. The main loop diagram applies to ALP300 protector with current specification of 1/5A/25A/100A;

4. The protector model is only for reference. The additional functions may be selected according to the need. For the unwanted functions, they are not connected. After the protector is powered on, 95 and 96 relays are closed.

9 保护功能设置及说明 Setting and description of protection functions

9.1 保护功能参数设置:

Setting of protection function parameters:

表 8
Table 8

功能 Function	项目 Item	内容 Content
起动超时保护 Start time-out protection	起动时间范围 Starting time range	0.1s~600.0s
	动作时间 Actuation time	瞬动 Transient dynamic
	保护动作方式 Actuation method	脱扣 trip
过载保护 Overload protection	不动作特性 Non-action characteristic	<120%Ie, 2h 内不动作 <120%Ie, failure to actuate
	动作特性 Action characteristic	>120%Ie, 1h 内延时动作 >120%Ie, delay to actuate within 1h
	脱扣级别 Tripping level	1, 2, 3, 5, 10, 15, 20, 25, 30, 35, 40
	报警值域 Alarm range	1%~99%
	过载保护方式 Over-load protection mode	报警、脱扣 Alarm、trip
过压保护 Over-voltage protection	动作值整定范围 Setting range of operating value range	(110%~150%)Ue
	延时时间整定范围 Setting range of delay time	0.1s~600.0s, 级差 0.1s 0.1s~600.0s, range 0.1s
	保护动作方式 Actuation method	脱扣 trip
欠压保护 Under-voltage protection	动作值整定范围 Setting range of operating value	(55%~90%)Ue
	延时时间整定范围 Setting range of delay time	0.1s~600.0s, 级差 0.1s
	保护动作方式 Actuation method	脱扣 trip
堵转保护 Locked-rotor protection	动作值整定范围 Setting range of operating value	(100%~700%)Ie
	延时时间整定范围 Setting range of delay time	0.1s~600.0s, 级差 0.1s
	保护动作方式 Actuation method	脱扣 trip
阻塞保护 Blocking protection	动作值整定范围 Setting range of operating value	(100%~700%)Ie
	延时时间整定范围 Setting range of delay time	0.1s~600.0s, 级差 0.1s
	保护动作方式 Actuation method	脱扣 trip
欠载保护 Under-load protection	动作值整定范围 Setting range of operating value	(10%~99%) Ie
	延时时间整定范围	0.1s~600.0s, 级差 0.1s

	Setting range of delay time	
	保护动作方式 Actuation method	脱扣 trip
不平衡保护 Unbalance protection	动作值整定范围 Setting range of operating value	10%~99%
	动作时间 Actuation time	0.1s~600.0s, 级差 0.1s
	保护动作方式 Actuation method	报警、脱扣 trip
接地/漏电保护 Earthing/leakage protection	整定值范围 Setting range	30~1000mA
	延时时间 Delay time	0.1s~600.0s, 级差 0.1s
	保护动作方式 Actuation method	脱扣 trip
短路保护 Short-circuit protection	短路整定值 Short circuit setting value	(400%~700%) Ie
	动作时间 Actuation time	0.1s~600.0s, 级差 0.1s
	保护动作方式 Actuation method	脱扣 trip
外部故障保护 External fault protection	动作时间 Actuation time	0.1s~600.0s, 级差 0.1s
	保护动作方式 Actuation method	脱扣 trip
断相保护 Phase failure protection	动作时间 Actuation time	0.1s~600.0s, 级差 0.1s
	保护动作方式 Actuation method	脱扣 trip

9.2 保护功能说明 Description of protection functions

各保护类型起作用时间段: Reacting time frame of all protection types:

表 9

保护类型 Type of protection	起作用时段 Working periods
外部故障、过压、欠压 External fault, Over-voltage, Under-voltage	停车 Stop
外部故障、过压、欠压、断相、堵转、漏电/接地、起动超时 External fault, Over-voltage, Under-voltage, phase failure, locked-rotor, leakage/ earthing and start time-out	起动 Start
外部故障、过压、欠压、断相、漏电/接地、过载、不平衡、阻塞、欠载、短路 External fault, Over-voltage, Under-voltage, phase failure, leakage/ earthing, overload, unbalance, blocking, under-load, short circuit	运行 Running

■ 起动超时保护 Starting overtime protection

当电动机起动时间达到用户设定的起动时间, 电动机的三相平均电流还大于设定的额定电流 1.1 倍时, 保护器按照内部设定的要求保护, 发出脱扣命令, 停止电机运行。

When the motor starting time reaches the user set starting time and the three-phase mean current of motor is more than 1.1 times of the rated current, the protector will send the tripping command according to the internal set requirements. Then, motor stops running.

■ 过载保护 Overload protection

当电动机在过负载情况下, 长时间超过其额定电流运行时, 会导致电动机过热, 绝缘降低而烧毁, 保护器根据电动机的发热特性, 计算电动机的热容量, 模拟电动机发热特性对电动机进行保护。

When the motor is overloaded and runs with the current more than the rated current for a long time, the motor will be overheated or may be burned up due to reduced insulation. The protector will calculate the motor's thermal capacity according to the motor's heating characteristics and protect the motor by simulating the characteristics.

过载保护电流-时间对照表 9, 过载特征曲线图 (K 曲线图) 如下图所示。

Overload protection current-time comparison table 9 and the overload feature curve diagram (K curve diagram) are shown below.

过载保护电流—时间对照表:

Overload protection current-time comparison table:

表 10
Table 10

可选择的脱扣曲线等级 K Selectable trip curve level, K	1	2	3	5	10	15	20	25	30	35	40
脱扣延时 (S) 误差 ±10% Trip delay error, s, ±10%	三相平衡的负载, 自冷态始 Balanced three-phase load, starting from the cold state										
额定值 $I_e \times 1.2$ Rated value $I_e * 1.2$	25	50	75	125	250	375	500	625	750	875	1000
$\times 1.5$	16	32	48	80	160	240	320	400	480	560	640
$\times 2$	9	18	27	45	90	135	180	225	270	315	360
$\times 3$	4	8	12	20	40	60	80	100	120	140	160
$\times 4$	2.26	4.52	6.78	11.3	22.5	33.8	45	56.3	67.5	78.8	90
$\times 5$	1.44	2.88	4.32	7.2	14.4	21.6	28.8	36	43.2	50.4	57.6
$\times 6$	1	2	3	5	10	15	20	25	30	35	40
$\times 7.2$	0.7	1.4	2.1	3.5	6.9	10.4	13.9	17.4	20.8	24.3	27.8

当保护器监测到电动机过载运行了, 保护器应在报警或脱扣 (延时) 设定时间内发出报警或脱扣信号。

When the protector monitors that the motor runs under overload, the protector shall send the alarm or tripping signal within the alarm or tripping (delay) set time.

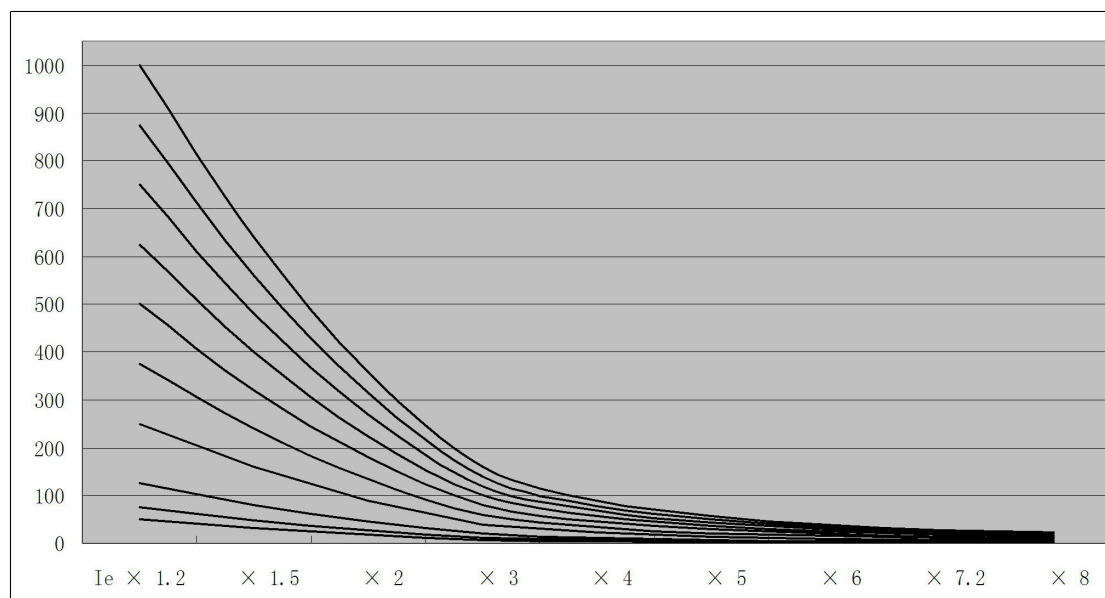

过载特征曲线图 (K 曲线图) Overload characteristic curve (curve K)

■ 堵转保护 (起动过流保护) Locked-rotor protection (starting overcurrent protection)

电动机在起动过程中, 如果由于负荷过大或自身机械原因, 造成电动机轴被卡住, 而未及时解除故障, 将造成电机过热, 绝缘降低而烧毁电机, 堵转保护适用于电动机起动发生此类故障时进行保护。

When the motor starts, if the motor shaft is clamped due to over-large load or mechanical cause and the fault is not eliminated in time, the motor will be overheated and burned up due to reduced insulation. The locked-rotor protection is used in case of such faults of motor starting.

■ 阻塞保护 Blocking protection

电动机在起动或运行过程中，如果由于负荷过大或自身机械原因，造成电动机轴被卡住，而未及时解除故障，将造成电机过热，绝缘降低而烧毁电机，堵转保护适用于电动机起动发生此类故障时进行保护，阻塞保护适用于电动机运行过程中发生此类故障时进行保护；当电流达到动作设定电流时，保护器及时在脱扣（延时）设定时间内脱扣，避免电机烧毁。

When the motor starts or runs, if the motor shaft is clamped due to over-large load or mechanical cause and the fault is not eliminated in time, the motor will be overheated and burned up due to reduced insulation. The locked-rotor protection is used in case of such faults of motor starting. The blocking protection is used in case of such faults during operation; when the current reaches the actuation set current, the protector will trip within the tripping (delay) set time to avoid motor burnout.

■ 欠载保护 Under-load protection

当电动机所带负载为泵式负载时，电动机空载或欠载运转会产生危害，保护器提供欠载保护，当三相的平均电流与额定电流的百分比低于设定值时，保护器应在脱扣（延时）设定时间内脱扣。

When the load of motor is pump load, there may be hazard due to motor no-load or underload running and the protector provides the underload protection. When the percentage of the three-phase mean current and rated current is less than the set value, the protector will trip within the tripping (delay) set time.

■ 不平衡保护 Unbalance protection

电动机运行时，三相电流不平衡率达到保护设定值时，保护器按照设定的要求保护，发出报警或脱扣信号，使电动机的运行更加安全。三相不平衡率表示三相电流与平均电流的最大差值/额定电流与平均电流的最大值的比值。

When the motor runs and the three-phase current unbalance rate reaches the protection set value, the protector will provide the protection according to the set requirements and send the alarm or tripping signal. Thus, the motor will run more safely. The three-phase unbalance rate refers to the specific ratio of maximum difference value between three-phase current and mean current/rated current and the maximum mean current.

动作时间误差：在动作时间定值 $\pm 10\%$ 范围内。

Actuation time error: within $\pm 10\%$ of actuation time set value.

保护动作特性：当不平衡率 $>$ 设定值时动作。

Protection actuation characteristic: when unbalance rate $>$ set value, it is actuated.

■ 接地/漏电保护 Earthing/ leakage protection

保护器具备接地保护和漏电保护功能（用户只能选择其中的一种）。接地电流采用三相电流矢量和叠加而成，漏电电流通过增加漏电互感器，检测到漏电电流大于设定的故障电流值，则保护器在脱扣（延时）设定时间内脱扣，以保证人身安全。

The protector has functions of ground protection and leakage protection (the user can only select one). The ground current is overlaid by three-phase current vector sum. If the leakage current is more than the fault current, which is detected by increasing leakage transformer, the protector will trip within the tripping (delay) set time to guarantee personal safety.

■ 短路保护 Short-circuit protection

当电动机运行电流超过设定的保护电流时保护器按设定的要求进行保护，在脱扣（延时）设定时间内脱扣。

When the motor running current is more than the set protection current, the protector will provide the protection according to the set requirements. It trips within the tripping (delay) set time.

■ 外部故障保护 External fault protection

当有外部故障出现时，外部故障开关量闭合，则保护器检测到有外部故障信号输入，在脱扣（延时）设定时间内脱扣。

In case of any external fault, the external fault switching is closed. Then, the protector detects that there is external signal input. It trips within the trip (delay) set time.

■ 断相保护 Phase failure protection

断相故障运行时对电动机的危害很大，当电动机发生断相时，保护器按照设定的要求保护，发出脱扣指令，使电动机的运行更加安全。

There is large hazard for the motor due to open-phase operation in fault. If the motor is open phase, the protector will provide the protection according to the set requirements and will send the trip command. Thus, the motor runs more safely.

注：4~20mA 模拟量输出中 20mA 对应 2 倍保护器额定电流（P055）。

Note: 20mA in 4 ~ 20mA analog output corresponds to twice of protector's rated current (P055).

10 注意事项 Cautions

- 1、一次回路，三相电流穿线方向需一致，否则将导致接地保护出错。
1.For the primary circuit, three-phase current threading direction shall keep consistent, or else, the ground protection will be in error.
- 2、当保护器配有接地/漏电保护功能时，从漏电互感器引入保护器的导线建议采用屏蔽导线，否则可能导致测量数据不准确。
2.When the protector is equipped with ground/leakage protection function, the protector wire from the leakage transformer shall be shielded conductor, or else, the measured data may be incorrect.
- 3、应合理设定保护器的额定电流（P055），若此设定值低于电动机的正常额定工作电流值，则可能会导致电动机无法正常起动；高于电动机的正常额定工作电流值，则电动机出现故障时保护器可能无法进行正常保护。
3.The rated current (P055) of the protector shall be set rationally. If the set value is less than the normal rated working current, the motor may not start normally; if the set value is more than the normal rated working current, the protector cannot provide the normal protection in case of motor fault.
- 4、保护器一旦发生脱扣动作，在故障排除后，重新起动电动机前，需对保护器

进行复位，否则将无法起动电动机。

4.If the protector trips, after the fault is eliminated and before the motor is started, please reset the protector, or else, the motor cannot be started.

5、电机冷却时间：30分钟。电机过载保护动作后（故障显示为hEAt）由于热累积，冷却后方可复位。

5.Motor cooling time: 30min. After the motor overload protection actuated (fault displayed as hEAt), after cooling, it can rest due to heat accumulation.

6、在现场实际使用中，由于保护器的参数设置不合理，可能会导致电动机一起动就保护或无保护作用，此时，可将所有保护功能都关闭，根据保护器在电动机正常运行时测量得到的各种参数对保护器的各种保护参数进行重新设定。

6.In the actual use on the site, as the protector parameter setting is not rational, the motors may be protected together or are not protected. At this moment, all protection functions will be off. All protection parameters of the protector are set again according to all parameters measured during motor normal operation.

7、若保护器设定的各种保护参数是合适的，但电动机一起动保护器就动作，则此时，可根据保护器显示的动作代码来查找故障原因。

7.If all protection parameters of the protector are appropriate, once the motors actuate together, the protector will work. At this moment, the fault cause is searched according to the actuation code of protector.

8、保护器在出厂时的各种设置参数采用默认设置（用户特别要求除外），用户在实际使用中可根据实际需要各种保护功能打开，并对各种参数进行设置。

8.The protector parameters are defaulted during delivery (except the user's special requirements). The user may enable all protection functions according to the actual need and set all parameters.

9、如果现场一次侧电流为1000A，外置互感器为1000A/5A，再接入保护器时，选用电流规格为5A的保护器，并设置CT变比为200。

9.If the primary current is 1000A, the external transformer is 1000A/5A. When the protector is connected again, the protector with 5A of current is selected and CT transformation ratio is 200.

11 订货范例 Order sample

例： 型 号：ALP300-25/CLM

辅助电源：AC 220V

电机额定电流：6.3~25A

应用场合：三相电机

附加功能：RS485 Modbus 通讯、零序电流测量、DC4~20mA 模拟量输出

Example: Model: ALP300-25/CLM

Auxiliary power supply: AC220V

Rated current of motor: 6.3-25A

Application: three-phase motor

Additional functions: RS485 Modbus, zero sequence current measurement, DC analog output 4-20mA